

# Hangers & Reinforcements

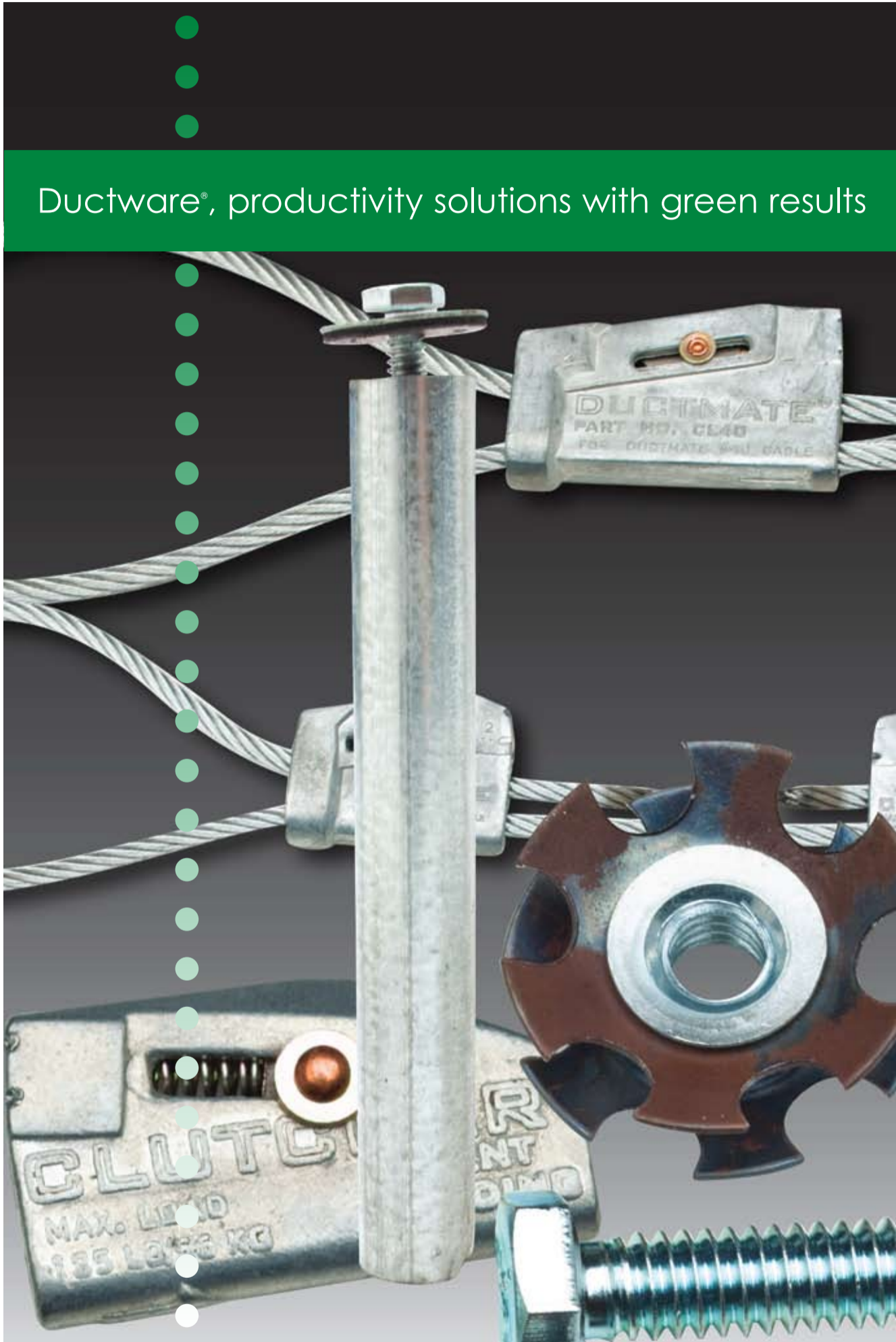

Ductware®, productivity solutions with green results

Hangers & Reinforcements

## Hanger Systems

### Isolation Hanger

RUBBER PREVENTS VIBRATION NOISE TRANSMISSION FROM AIR DUCTS AND OTHER VENTILATION DEVICES TO PARTS OF THE BUILDING.

- For 3/8" Threaded Rod
- Overall Length 5-7/8" (150mm)
- Max. Width 1-13/16"x1-13/16" (45x45mm)
- Load-Bearing Capacity: 1100 lbs (500 k)
- Packing Unit: 50 Pcs./Case @ 37 lbs (17KG)/Case

The sturdy tension bracket has a much greater load-bearing capacity than the corresponding threaded rods.

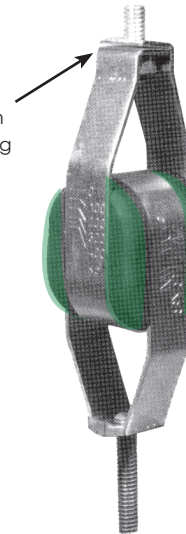

The rubber padding which prevents vibrations from being transmitted is 1-3/4" (45 mm) x 2" (50 mm) and 2-3/16" (55 mm) thick.

Part No. DM2723SI

## Round Duct Strap Bracket

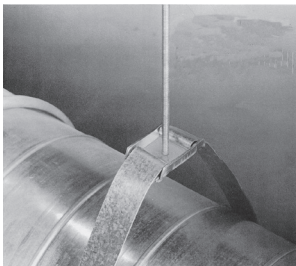

The ideal way to hang round ductwork. No Tools needed. The steel strap is hand bent into the bracket which is self loading.

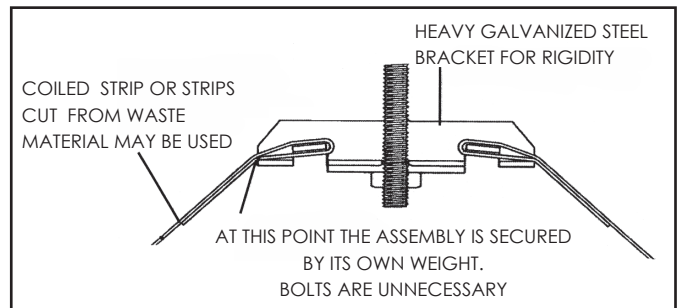

### PART NUMBER VARIATIONS

Part No.	Alloy
DM4703	GA = Galvanized S4 = 304 Stainless Steel S6 = 316 Stainless Steel

PACKAGING QTY: 200 Pcs./Case @ 27.5 Lbs. (12.5 KG)/Case

### SPECIFICATIONS

- CAN BE USED WITH DUCTWORK UP TO A 50" IN DIAMETER
- FITS STRAPPING 1" IN WIDTH, GAUGES 18 - 22
- CAN BE USED WITH ROD 5/16" - 3/8"
- WILL HOLD UP TO 660 LBS (300KG)

## ROUND DUCT HANGER

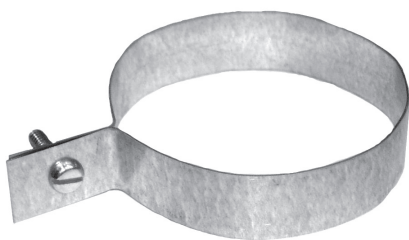

### Specifications:

- Manufactured from 20 gauge galvanized metal.
- Bolt is a 1/4" - 20 x 1" machine screw, pan head, zinc plated, slotted, with hex nut.

Part Number Variation: RDH\_\*GA20

\* Insert desired diameter in sizes 4" - 18", 20", 22", 24"

## Hangers & Reinforcement

# Clutcher®

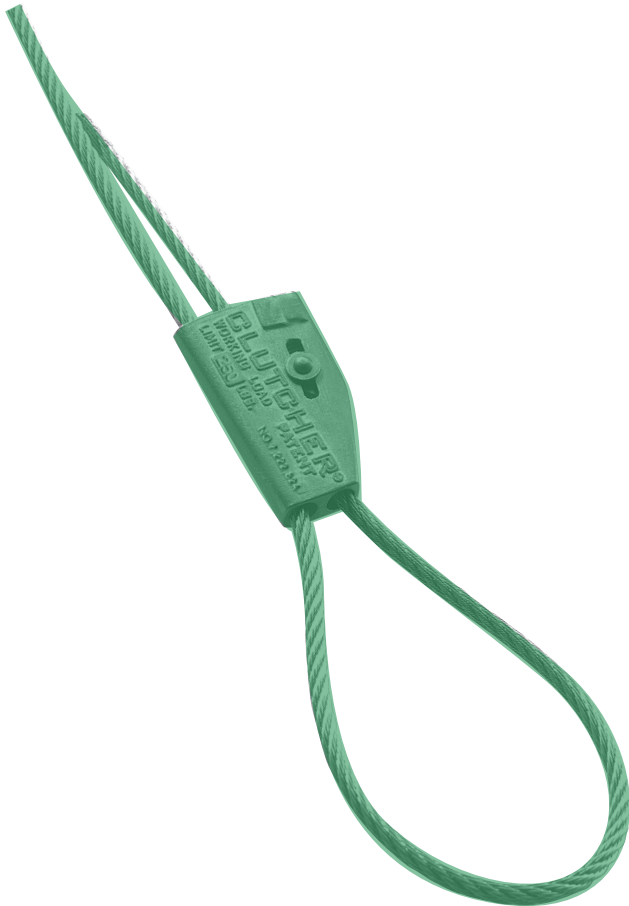

- Can be used on a variety of mechanical systems
- Cable & Clutcher sold separately
- Eliminates the need to stock pre-cut cable
- Tapered bore design for fast and easy installation
- Easily adjust hanging height by hand
- Extremely Strong
- Offers a 5 to 1 safety factor
- Available in variety of sizes for different weights
- Items can be hung at angles up to 60° from vertical
- Lightweight design reduces the risk of on-site accidents
- Aesthetically pleasing
- Seismic tested and conforms to ICC Code guidelines EG284
- Available in galvanized steel only

### LOAD RATINGS

Size	Box/Quantity	Bag/Quantity	Bag/Boxes
CL10	200	10	20
CL20	150	10	15
CL30	50	5	10
CL40	25	5	5

### DECLUTCHER



CLTOOL1020

### PACKAGING INFO

Clutcher Part #	Load Rating	Recommended Ductmate Steel Cable *
CL10	125lbs.	WR10
CL20	250lbs.	WR20
CL30	650lbs.	WR30
CL40	1250lbs.	WR40

\* Must be used in conjunction with Ductmate Steel Cable



## Hangers & Reinforcement

# STEEL CABLE

Ductmate steel cable is designed for the suspension of HVAC and other mechanical systems. This product has been designed to be used in conjunction with Ductmate's Cablemate Systems.

- Aircraft quality zinc coated steel cable
- Superior strength
- Supplied in coils to reduce waste
- Coils were designed for strength and ease of use
- Available in a variety of sizes and lengths

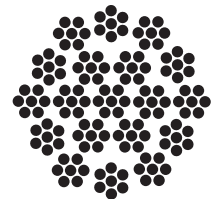

7x19

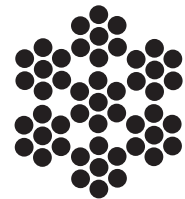

7x7

### TECHNICAL and PACKAGING INFORMATION

#### 7x7

Part #	Description	Breaking Load	Length
WR10500	#10 Steel Cable	826 lbs. (specified)	500'/Spool
WR101000	#10 Steel Cable	826 lbs. (specified)	1000'/Spool
WR20500	#20 Steel Cable	1697 lbs. (specified)	500'/Spool
WR201000	#20 Steel Cable	1697 lbs. (specified)	1000'/Spool

#### 7x19

Part #	Description	Breaking Load	Length
WR30500	#30 Steel Cable	4199 lbs. (specified)	500'/Spool
WR301000	#30 Steel Cable	4199 lbs. (specified)	1000'/Spool
WR40500	#40 Steel Cable	7065 lbs. (specified)	500'/Spool
WR401000	#40 Steel Cable	7065 lbs. (specified)	1000'/Spool

Also available:

Part #	Description
HFCCS	Corner Cleat Saddle for rectangular duct edges
HFWR	Steel Cable Cutter for WR10 & WR20 Steel Cable
CLTOOL1020	Declutcher for CL10 & CL20

Steel Cable CUTTER



HFWR



## Reinforcements

### EASYROD Tie Rod Construction

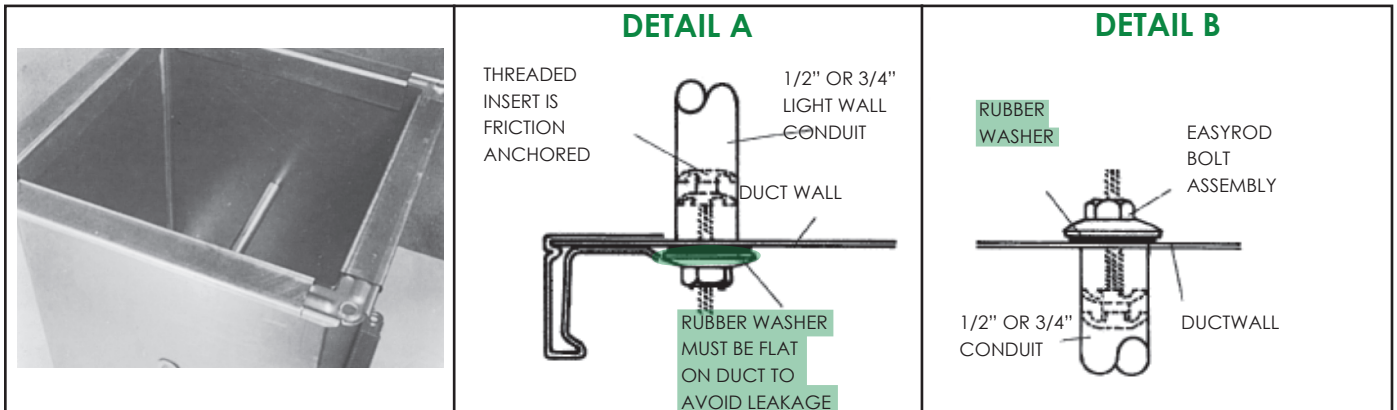

#### TIE ROD CONSTRUCTION HARDWARE/EASYROD

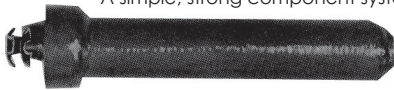

A simple, strong component system to make the installation of tie rods faster. Can be used for both positive and negative pressure.

#### NEW MAGNETIC TIE ROD ANCHOR SET

Innovative device to help install the bolt anchor into pipe. Heavy cast steel with magnetic tip insures a fast, strong friction fit.

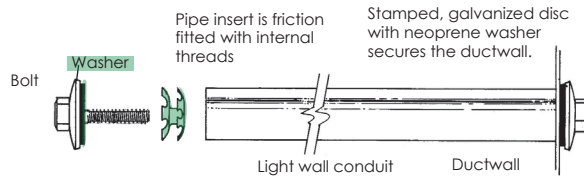

- Pull out strength of 900 lbs
- Quickly inserts into ductwork
- Can be used for both Positive and Negative pressure

PART NO.	DESCRIPTION	PACKING UNIT	UNIT WEIGHT
EZ50	BOLT, WASHER, INSERT FOR 1/2" EMT CONDUIT	250 SETS	9 LBS (4.1 KG)
EZ75	BOLT, WASHER, INSERT FOR 3/4" EMT CONDUIT	250 SETS	10 LBS (4.5 KG)
EZTOOL	MAGNETIC TIE ROD ANCHOR SET	1 EA.	2 LBS (.9 KG)

### EASYSTUD TIE ROD CONSTRUCTION

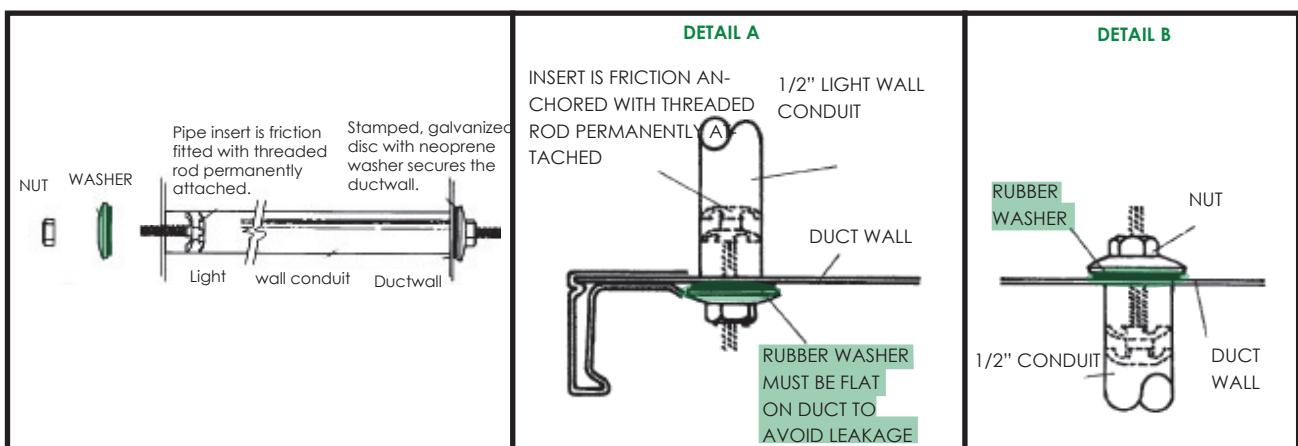

- Pull out strength of 600 lbs
- Quickly inserts into ductwork
- Can be easily installed by one person
- Can be used for both Positive and Negative pressure

PART NO.	DESCRIPTION	PACKING UNIT	UNIT WEIGHT
ES50	INSERT WITH THREADED ROD ATTACHED, WASHER, NUT, FOR 1/2" EMT CONDUIT	250 SETS	10.5 LBS (4.1 KG)
ESTOOL	INSERTER TOOL FOR EASYSTUD	1 EA	2 LBS (.9 KG)