

Ductware

Clutcher™

by Ductmate



Mechanical System Hanger

Seismic Tested & Conforms to ICC Code Guidelines EG284

- Can be used on a variety of mechanical systems
- Wire & Clutcher sold separately
- Eliminates the need to stock pre-cut wire
- Tapered bore design for fast and easy installation
- Easily adjust hanging height by hand
- Extremely strong patented design
- Offers a 5 to 1 safety factor
- Available in a variety of sizes for different weights
- Items can be hung at angles up to 60° from vertical
- Lightweight design reduces the risk of on-site accidents
- Aesthetically pleasing
- Can be used for Seismic Applications

Ductware®
Productivity solutions with green results

DESCRIPTION

Wire rope hanging system for HVAC and other mechanical applications.

BASIC USE

Labor saving, versatile means for the suspension of static load HVAC and other mechanical applications indoors.

SPECIAL CHARACTERISTICS

- Can be used on a variety of mechanical systems
- Wire and Clutcher sold separately
- Eliminates the need to stock pre-cut wire
- Tapered bore design for fast and easy installation
- Easily adjust hanging height by hand
- Extremely strong patented design
- Offers a 5 to 1 safety factor
- Available in a variety of sizes for different weights
- Items can be hung at angles up to 60° from vertical
- Lightweight design reduces the risk of on-site accidents
- Aesthetically pleasing

TECHNICAL INFORMATION

Clutcher

HOUSING: Zinc Cast

SPRINGS: Steel

WEDGES: Hardened Steel

END CAP: Stamped Plated Steel

Wire Rope

This system requires Ductmate Wire Rope be used to meet testing and product specifications.

Clutcher Part No.	Load Rating (kg)	Wire Rope	Specified Breaking Load (Kg)
DW-CL10	56	DW-WR10	375
DW-CL20	113	DW-WR20	770
DW-CL30	295	DW-WR30	1904
DW-CL40	565	DW-WR40	3505

PRODUCT DISCLAIMER

Ductmate Industries, Inc. is not liable for consequential, incidental or special damages. There are no statutory or implied warranties including the warranties for fitness for a particular purpose and merchantability. There are no warranties other than as set forth below and Ductmate Industries, Inc. neither assumes nor authorizes any person to assume any liability or other obligation in connection with the Clutcher system.

This product must be used in conjunction with the correct diameter Ductmate supplied wire rope spools. Ductmate will not guarantee the strength or working loads when used in conjunction with any other wire or system. It is the End User's responsibility to test this system for each specific application.

- Never exceed the working range
- Loads should be carried evenly across all the hanging points
- Always check that the locking mechanism is fully engaged
- The Clutcher system should not be used for lifting
- Do not use or apply paint, lubricants or other coatings to the hanging system
- Do not use in corrosive environments

PACKAGING INFORMATION

Size	Box Quantity	Bag Quantity	Bag/Boxes
DW-CL10	200	10	20
DW-CL20	150	10	15
DW-CL30	50	5	10
DW-CL40	25	5	5

WORKING LOAD LIMITS FOR NON-VERTICAL SUPPORT

Angle from Vertical in Degrees	Working Load Limits			
	DW-CL10	DW-CL20	DW-CL30	DW-CL40
0	56.7	113.4	294.8	567.0
5	56.5	112.9	293.7	564.8
10	55.8	111.7	290.3	558.4
15	54.7	109.5	284.8	547.7
20	53.3	106.6	277.1	532.8
25	51.4	102.8	267.2	513.9
30	49.1	98.2	255.3	491.0
35	46.4	92.9	241.5	464.4
40	43.5	86.9	225.8	434.4
45	40.1	80.2	208.5	400.9
50	36.4	72.8	189.5	364.5
55	32.5	65.0	169.1	325.2
60	28.3	56.7	147.4	283.5

TESTING

Ductmate's Clutcher has been tested to a 5:1 safety factor.

WIRE ROPE DIRECTIONS INTO CLUTCHER

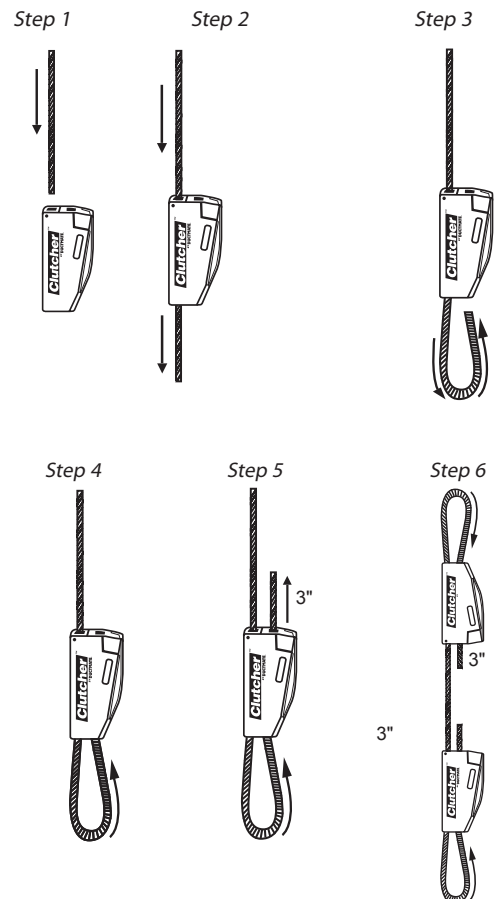

A 3" minimum length of wire must be left protruding from the locking mechanism.

PRODUCT GUARANTEE

All component parts of the Clutcher are guaranteed against defective material.

INSTALLATION INSTRUCTIONS

After the ductwork is leveled and the connection at the upper attachment secured with the Ductmate Wire Rope, then proceed with attaching the Clutcher to the object being suspended.

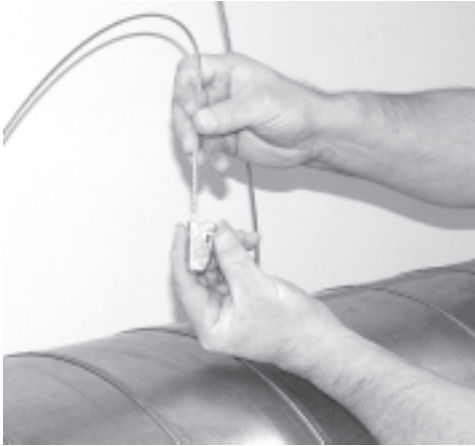

1. Insert wire rope through free flowing side of Clutcher.



4. Pull the wire to make the connection tight to the object being suspended.

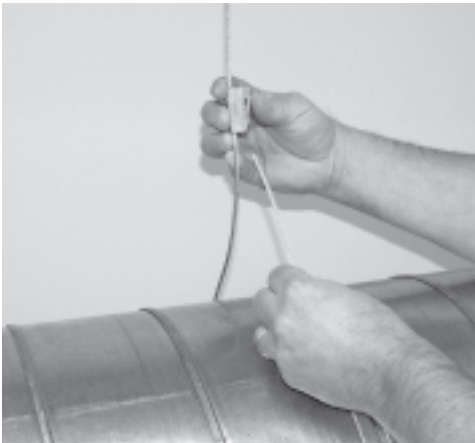

2. Wrap wire around object being suspended (round duct in this case).

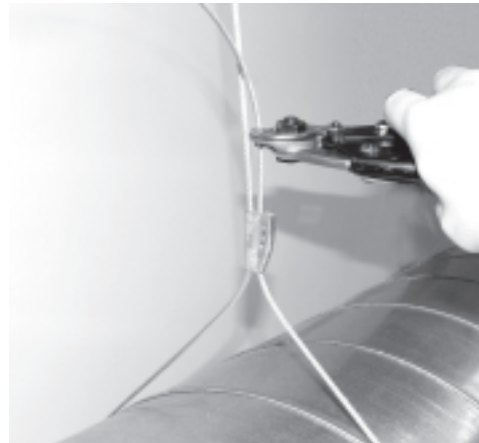

5. Cut the excess wire rope.

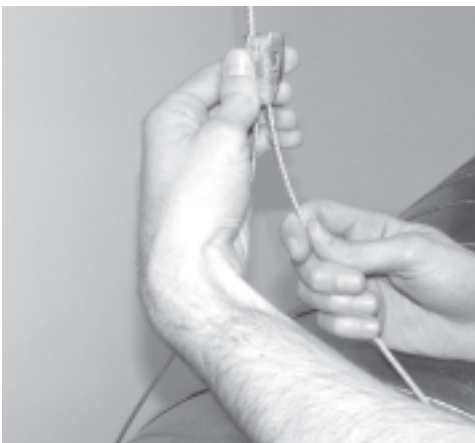

3. Thread Ductmate wire rope through the Clutcher's locking device.



6. Object is now successfully suspended.

ASSEMBLY METHODS

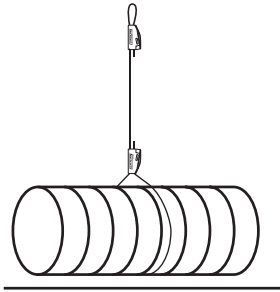

ROUND DUCT

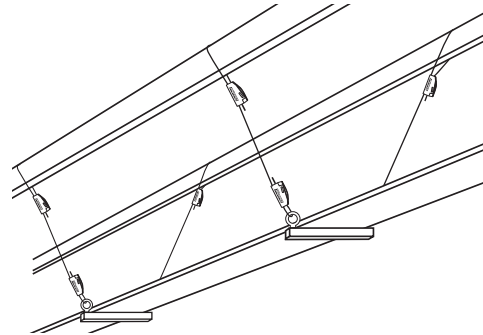

CABLE TRAYS

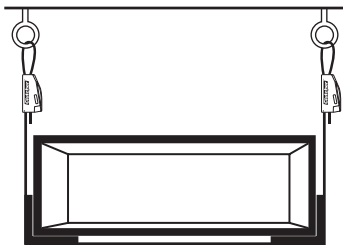

RECTANGULAR DUCT

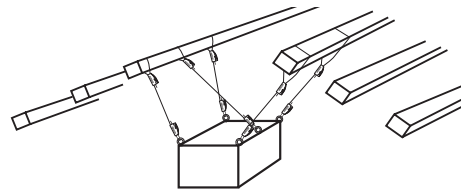

SIDE LOADINGS

Load to failure test after fatiguing each assembly for 100,000 cycles at 5HZ. This test performed by an outside independent testing company

CL10-1	669 lbs.	CL30-1	3838 lbs.
CL10-2	666 lbs.	CL30-2	3884 lbs.
CL10-3	851 lbs.	CL30-3	3396 lbs.
CL20-1	1226 lbs.	CL40-1	4887 lbs.
CL20-2	1538 lbs.	CL40-2	4614 lbs.
CL20-3	1344 lbs.	CL40-3	4328 lbs.

Wire Rope Part No.	Diameter (mm)	Configuration	Specified Breaking Load (Kg)
DW-WR10	2	7x7	375
DW-WR20	3.2	7x7	770
DW-WR30	4.8	7x19	1904
DW-WR40	6	7x19	3205

Test Number	1" Mandrel Test				Mode of Failure
	Breaking Load (lbs.)	Over 1" Mandrel			
	CL10	CL20	CL30	CL40	
1	990	1515	4780	6970	wire break at clutcher
2	940	1425	4620	6880	wire break at clutcher
3	945	1475	4600	7050	wire break at clutcher
4	950	1565	4970	7410	wire break at clutcher
5	930	1755	4840	7280	wire break at clutcher
Average	951	1547	4762	7118	

Test Number	Sharp Edge (3" Channel) Test				Mode of Failure
	Sharp Edge (3" Channel)	lbs.			
	CL10	CL20	CL30	CL40	
1	595	1065	2770	3530	wire break at sharp edge
2	605	1155	2560	3860	wire break at sharp edge
3	750	985	2360	3640	wire break at sharp edge
4	870	975	2730	3700	wire break at sharp edge
5	605	1110	2540	3810	wire break at sharp edge
Average	685	1058	2592	3708	

The 1" Mandrel Test and Sharp Edge Test (3" Channel) were conducted according to ASTM E-8 by independent testing companies.

Ductmate WR10 and WR20 7x7 galvanized steel cable used with the CL10 and CL20 clutchers. Ductmate WR30 and WR44 7x19 galvanized steel cable used with the CL30 and CL40 Clutchers.